

TECHNICAL MANUAL

300RCB Searchlight and Control System

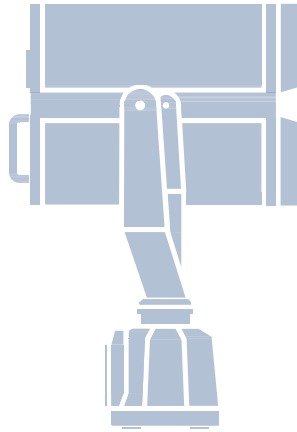

SINCE 1922

Den Haan Rotterdam



(Intentionally blank page)



Safety notes:

- Turn power off before inspection, installation or removal
- Keep combustible materials away from lamp
- Do not exceed 105% of rated voltage
- Allow lamp/fixture to cool before handling
- Do not use the searchlight if outer glass is scratched or broken

Damage due to inappropriate handling is not covered by the warranty.

This document contains proprietary information that is protected by copyright.
All rights reserved.

© Copyright, Den Haan Rotterdam B.V.
Version 1.3 Nov 2017

FOREWORD

Den Haan Rotterdam is a family company respected in 1922. Started as a small tinsmith, it has evolved into a globally respected producer of navigation lights, searchlights, air horns and a wide range of nautical lamps made from copper and brass. By introducing products with advanced LED-technology, DHR has safeguarded a visibly safe future for marine vessels in all weather conditions.

The brand-new 300RCB-series proves again that DHR has the know-how and know-why for adopting the best LED-technology available for searchlights. A perfect solution for tugs, workboats, high speed vessels and pilot boats. A big advancement, which uses a new revolutionary LED-chip having the highest lumen output per square mm². It boosts up to 20.000 lumens from an area less than a square centimetre. Combine this with an optical system consisting of a glass lens and a silver-mirror reflector, it creates the highest performing LED searchlight to date.

DHR believes that the 300RCB-series certainly adds value to the shipowner. An impressive optical system in combination with a robust and compact design, makes it a unique, distinctive and high-quality searchlight.

DEN HAAN ROTTERDAM B.V.



D.M. Den Haan
Managing Director

QUALITY STANDARDS



LED Technology



Focus Control



Excellent Optics



Light Weight Construction



Maintenance Friendly



IP66 Water Ingress Protection



TABLE OF CONTENTS

1. Mounting instructions	6
2. Maintenance	8
3. Specifications	9
4. Dimensions Searchlight	11
5. Photos Searchlight	12
6. Dimensions control panel	13
7. Wiring diagram searchlight	14
8. Wiring diagram control panel	15
9. Wiring diagram dual control panel	16
10. Wiring diagram switches / digital	17
11. Spare parts	18

1. MOUNTING INSTRUCTIONS



Warning!

Den Haan Rotterdam accepts no responsibility for any damage if the searchlight is installed incorrectly and/or used improperly. When in doubt consult a qualified electrical technician.

Mounting the panel

Place the control panel inside the wheelhouse, where it is protected against weather influences. The housing is especially constructed to be flush mounted in an instrument cabinet according the illustration below. The minimum space needed behind the panel is 60 mm. (depth)

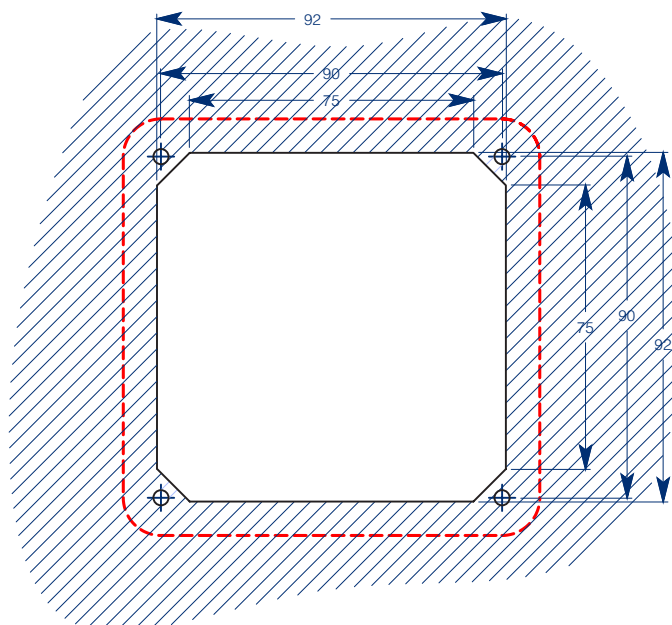

Searchlight installation

Install the searchlight in a horizontal upright position with sufficient space around the head of the searchlight to ensure it can move freely. The dimensions can be found on page 9.

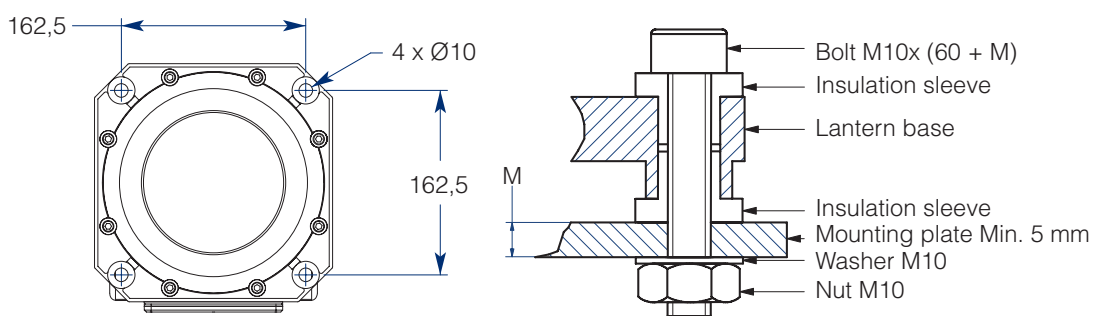

All dimensions in mm

Fasteners

- The permissible torque should be 8 Nm
- Use only A4-grade stainless steel

Caution!

Even though the housing is made of corrosion resistant materials, galvanic corrosion may still occur. To prevent galvanic corrosion use the supplied insulation sleeves to isolate the aluminium housing from other metal parts.

Electrical installation

Install the electrical wiring according to the wiring diagrams showing at pages 11 - 14. Keep the distance between the power supply and halogen lamp as short as possible. Long wires will increase a voltage drop near the halogen lamp, which affects the light output.

Cable glands

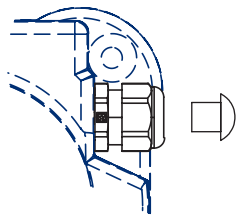

Remove the plug before placing the cable.
If no cable is connected leave the plug in place!

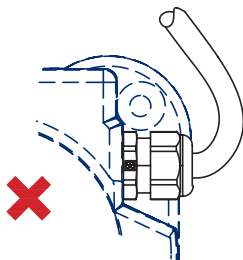

Cable too tight!
This gives unwanted stress at the sealing of the cable gland and water ingress will occur.

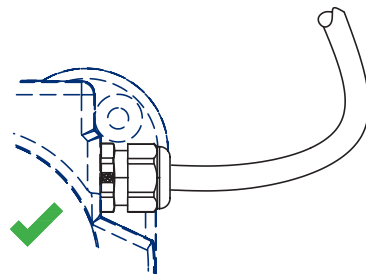

Include cable slack at the entering point of the cable gland

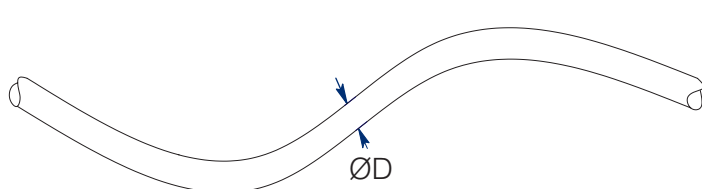

Preferred cable diameter D is 7 - 12 mm

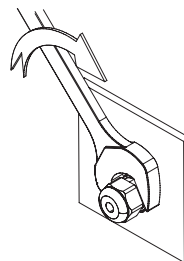

Replacing cable gland

- Use gasket between housing and cable gland
- Tighten firmly (6Nm) with wrench

Note

The cable glands on the searchlight prevent water ingress. Do not use (electrical) tape to cover the cable where it enters the cable gland as this will cause water ingress. Do not use a rubber or shrinkable cover on the cable gland to improve water tightness.

2. MAINTENANCE



Safety notes

- Handle with care
- Turn off main power
- Warning, LED is hot
- Do not touch the LED with your hands

Preventive maintenance

Clean the searchlight with clean water regularly. Do not use any aggressive cleaning agents. At least twice a year rub the dirt wiper, on top of the motor housing (see drawing below), in with silicone grease.

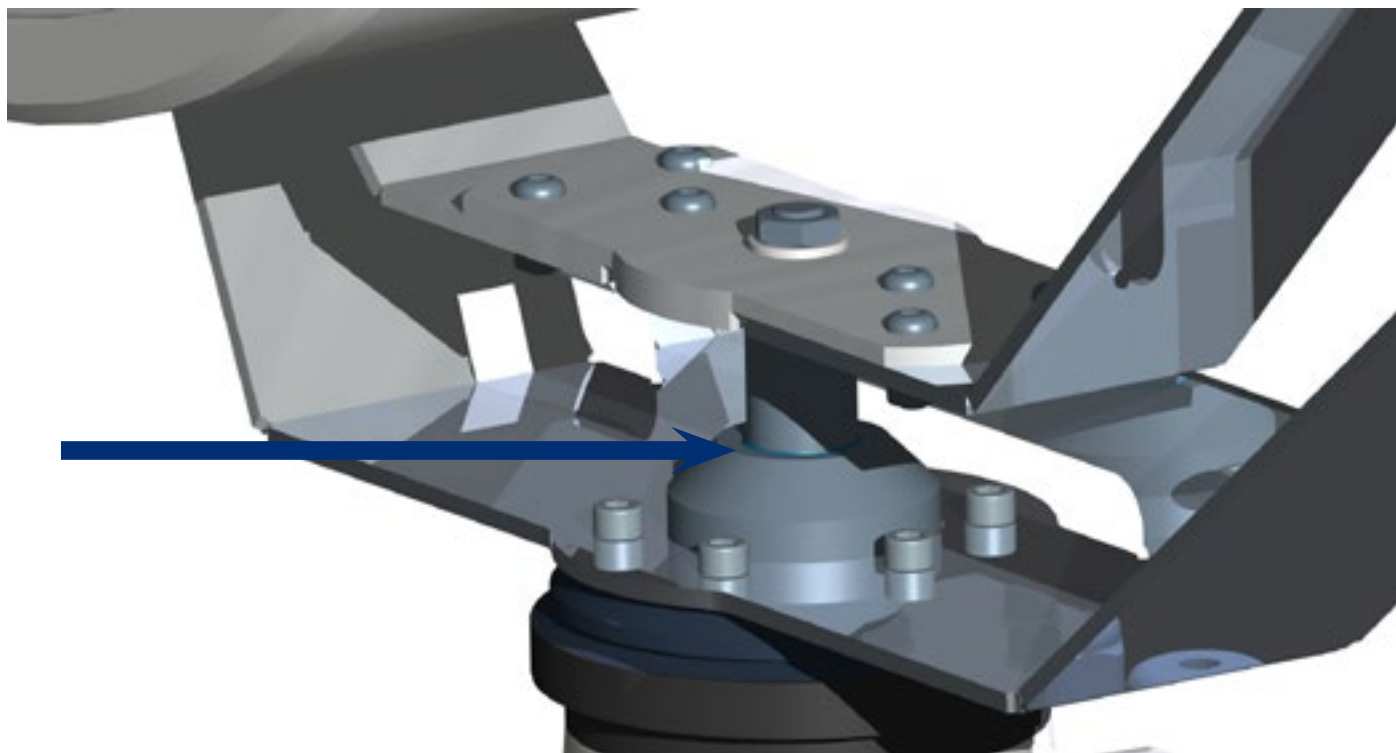

3. SPECIFICATIONS

Searchlight

Model	DHR300 Remote control	
Dimensions		
Height	758 mm	
Width	557 mm	
weight	28 kg	
Electrical		
LED-driver voltage	230 VAC	
Led driver wattage	240 Watt	
Control voltage	24 VDC	
Preferred cable type	H07RN-F	
Cable diameter	Ø 6-12 mm	
Optics		
Mirror	Parabolic mirror reflector Ø 300 mm	
Range	1732 m	
Focus (Beam angle at 50%)	From 4 ° up to 20°	
Luminous intensity	3.200.000 cd	
LED		
Model	Osram	
Luminous flux	up to 17.000 lm	
LED voltage (2 channels)	24 V ... 32 V @ 25°C	
LED wattage	240 W up to 360W	
Average life-time	10.000 h	
Color temperature	6200 K	
Base connection	four screws	
Heater		
Type	PTC-heater	PTC-heater with Fan
Voltage	24VDC	230VAC
Maximum wattage	70 W	250 W
Motor Unit		
Tilt	+ 20° / - 25°	
PAN	340°	
Speed left / right approx.	16 or 32°/ sec	
Speed up / down approx.	1,6 or 3,2° / sec	
Housing		
Material	Chromated seawater resistant aluminium	
Finish	UV resistant powder coating - White RAL9016	
Front glass	Hardened glass	
Sealings	Silicone	
Cable gland	M25x1.5	
Operating temperature	- 25° / + 40° C	
Ingress protection class	IP66 c/w Membrane vent	



Control panel

Model	PAN2016
Dimensions	
Depth	110 mm
Width	110 mm
Weight	0,25 kg
Electrical	
Voltage	24 VDC
Maximum wattage	5 W
Fuse (2x)	T5A
Electrical insulation class	III
Housing	
Front	Aluminium, anodized
Operating temperature	0° C / + 40° C
Storage temperature	-25° C / + 70° C

4. DIMENSIONS SEARCHLIGHT

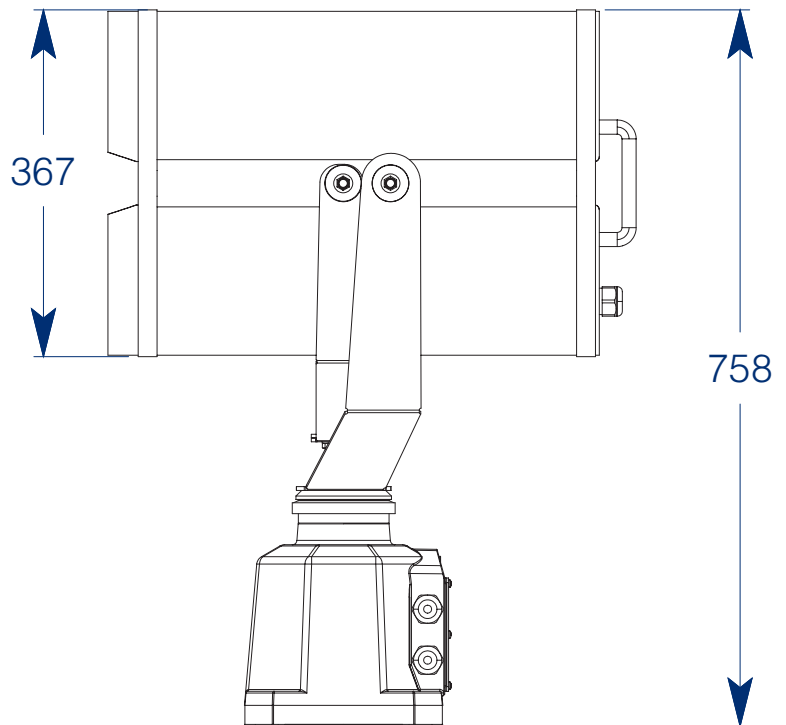
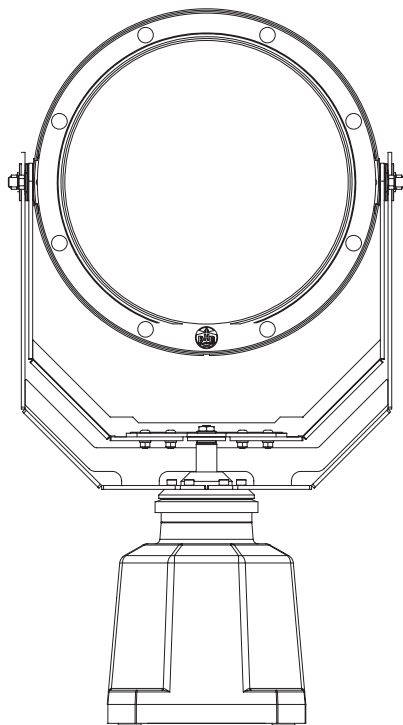
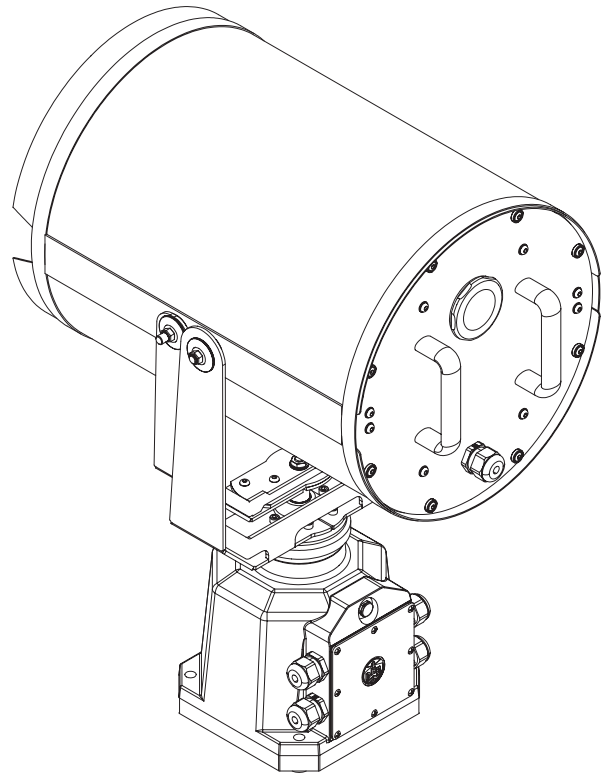
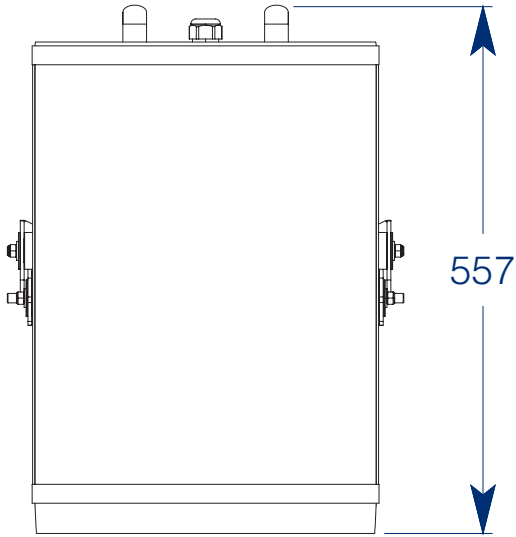

All dimensions are in mm.

5. PHOTOS SEARCHLIGHT



6. DIMENSIONS CONTROL PANEL

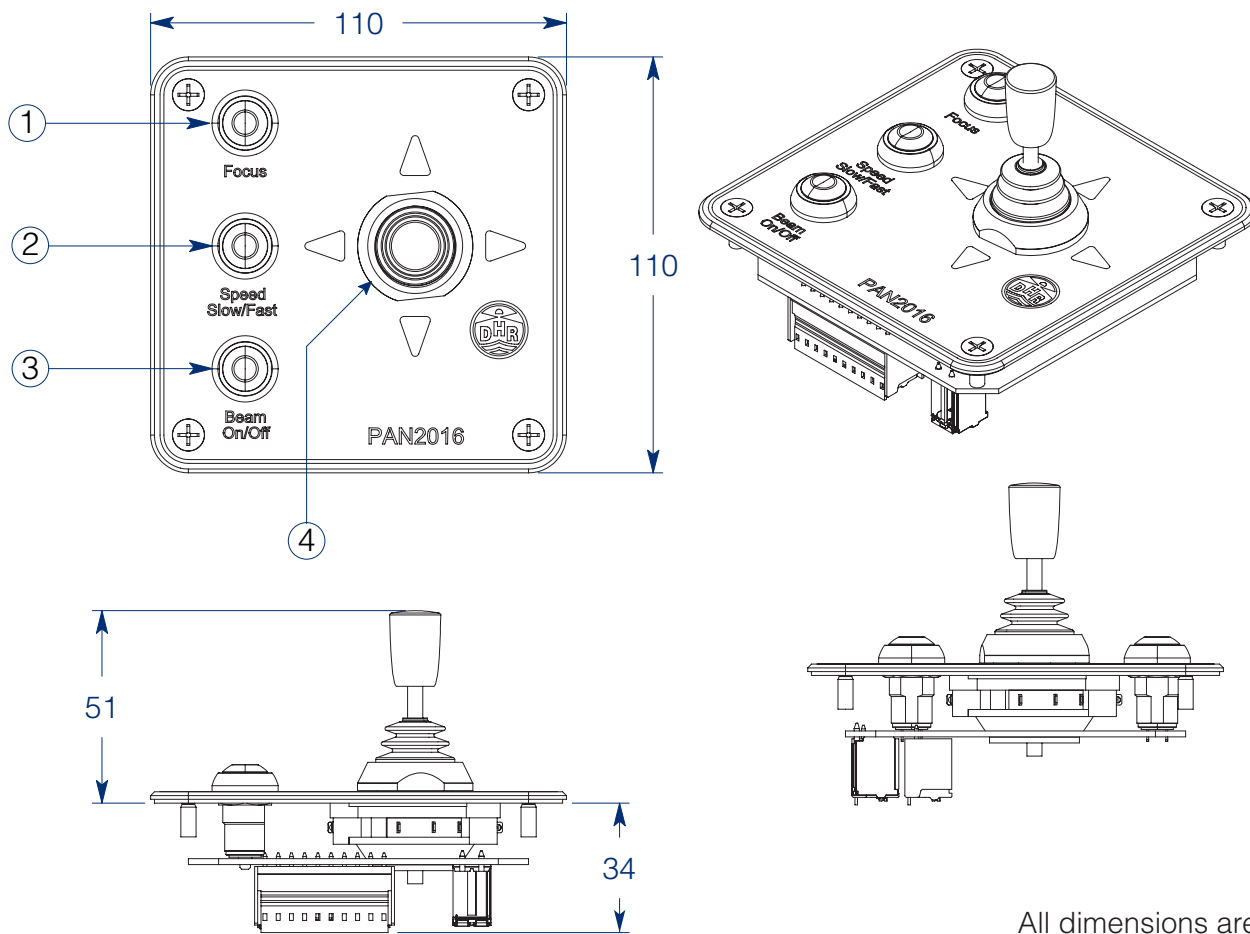

All dimensions are in mm.

Controls

1. FOCUS, controls with Joystick the beam angle.
2. SPEED, 50% or 100%
3. BEAM ON/OFF, switches the LED on or off.
4. JOYSTICK, controls the direction of the movement.

7. WIRING DIAGRAM SEARCHLIGHT

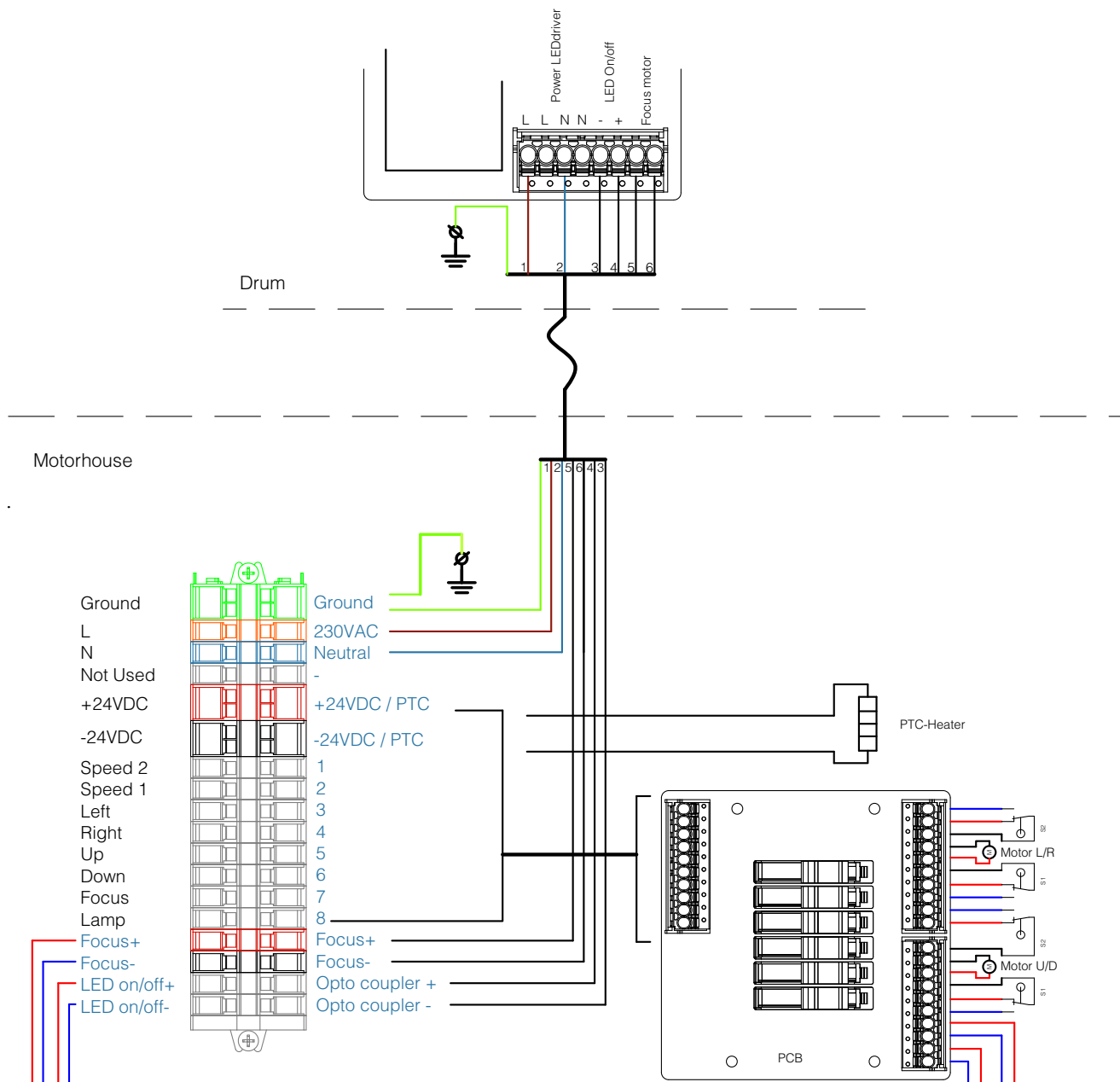

8. WIRING DIAGRAM CONTROL PANEL

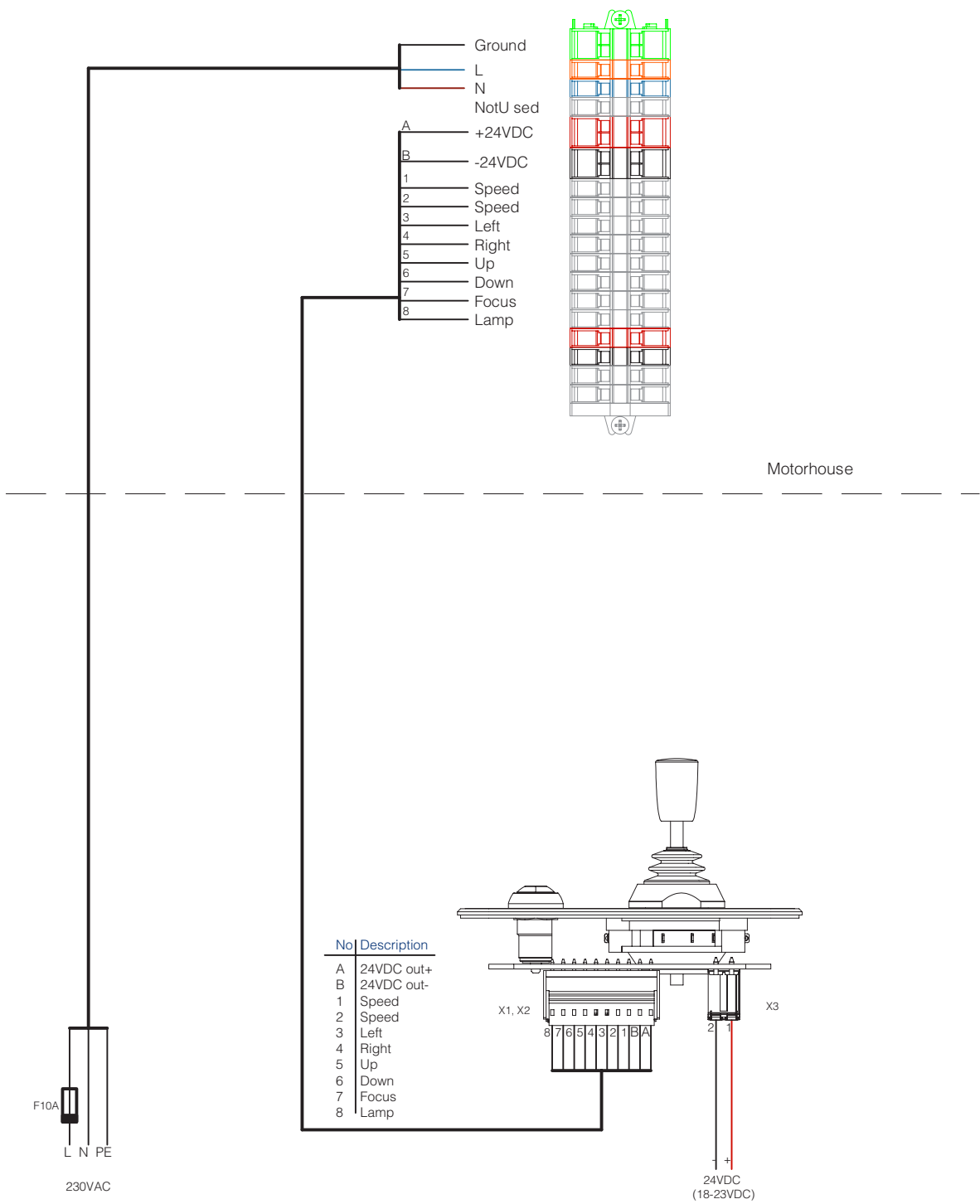

9. WIRING DIAGRAM DUAL CONTROL PANEL

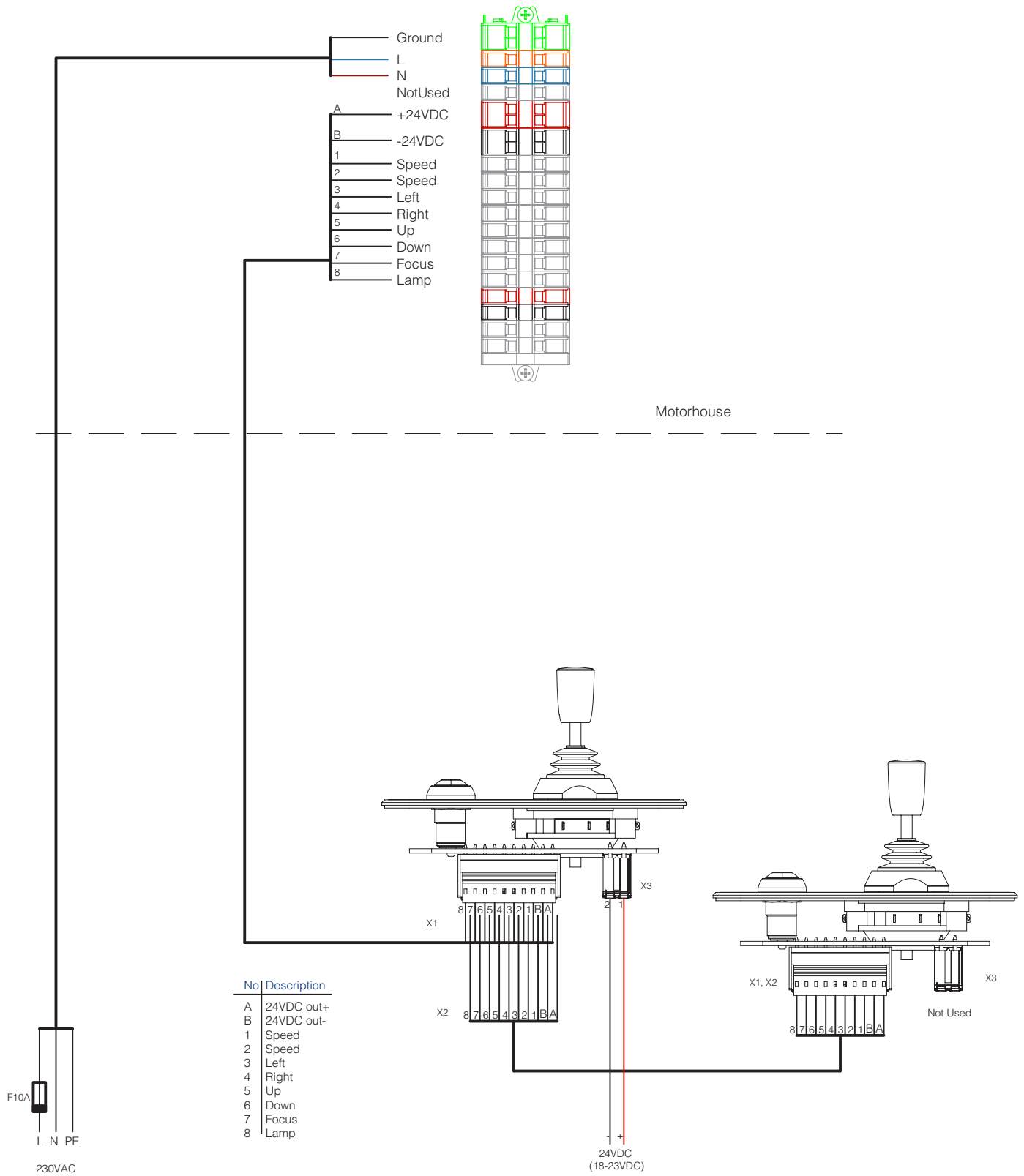

10. WIRING DIAGRAM SWITCHES / DIGITAL

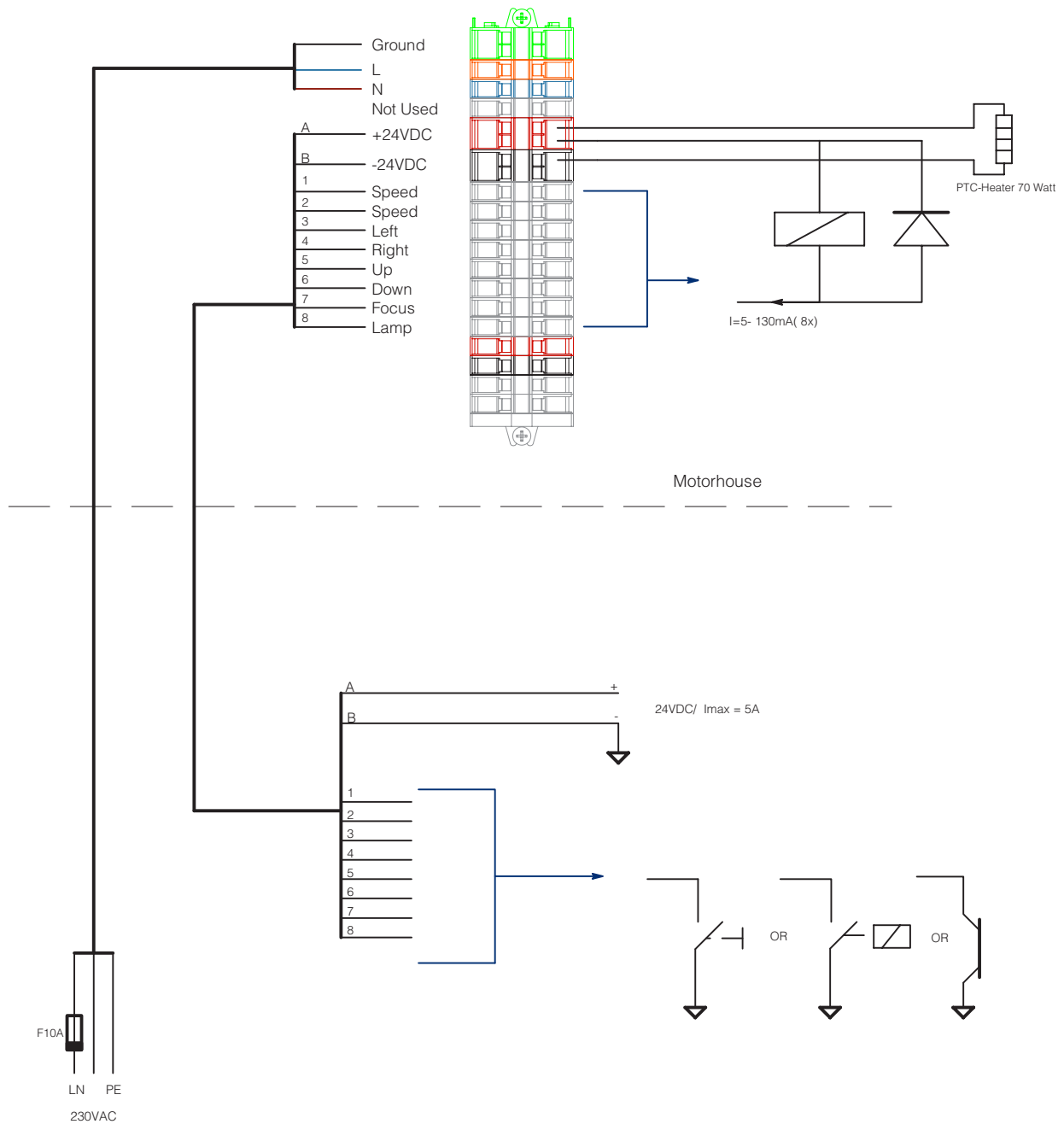

11. SPARE PARTS

Spare Part		
No	Description	Order code
1	LED Unit with heatsink	TBA
2	LED controller	H1CON-0300
3	LED driver	H1VOE-0200
4	Glass mirror 300 mm	30008
5	Front glass	30053
6	Motor frame RCB	Z4-PLA-0900
7	Control Panel	PAN2016



1

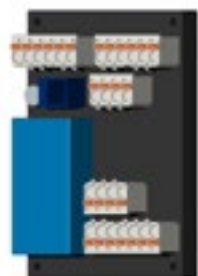

2



3

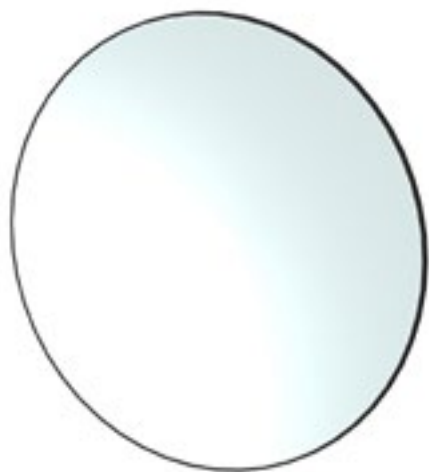

4

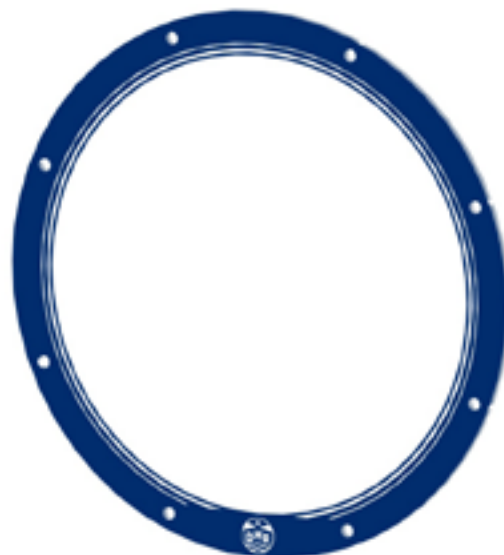

5

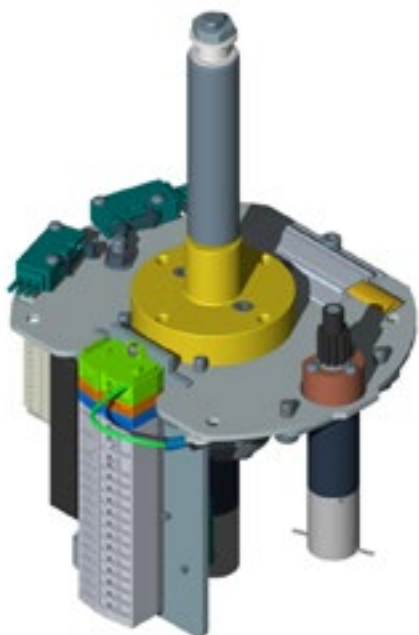

6



7

ADVANCED MARITIME SIGNALLING SOLUTIONS



Den Haan Rotterdam
Fascinatio Boulevard 1182
2909 VA Capelle a/d IJssel
The Netherlands
T +31 (0) 10 413 07 55
E sales@dhr.nl
www.dhr.nl